

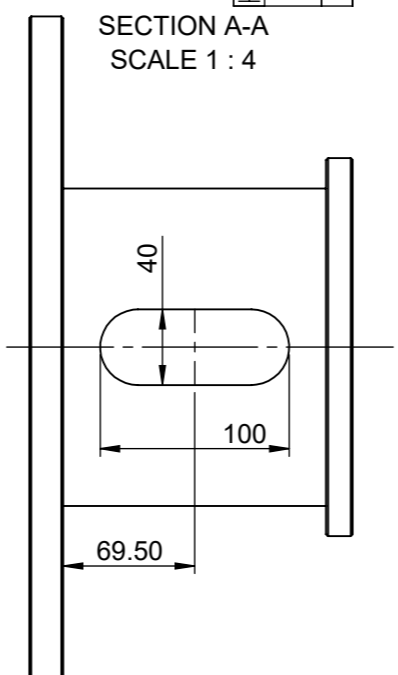

ECN	REVISION	DATE	MODIFICATION	DESIGN BY	APPROVE BY

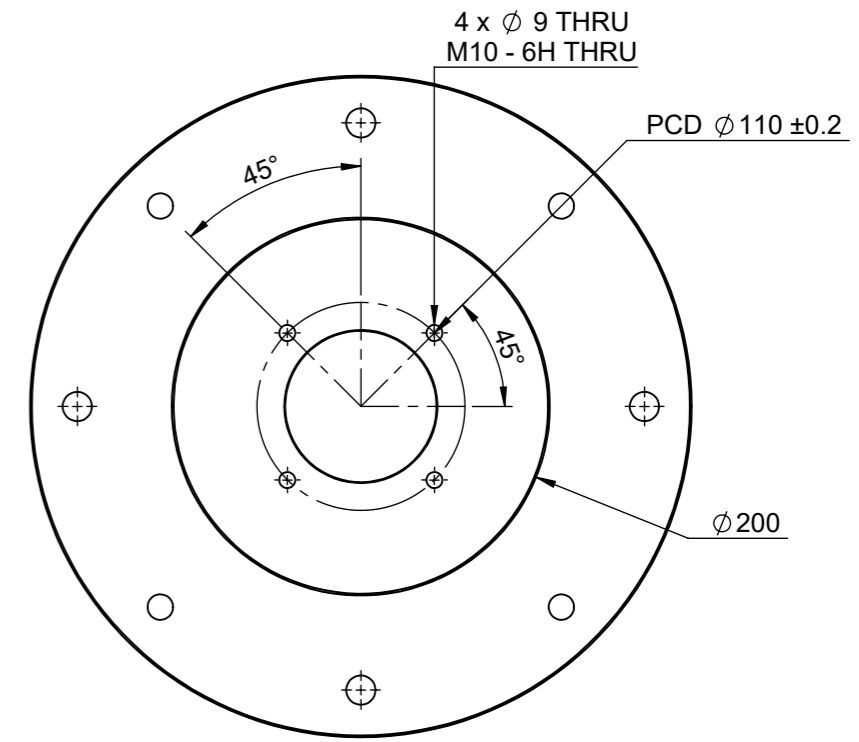
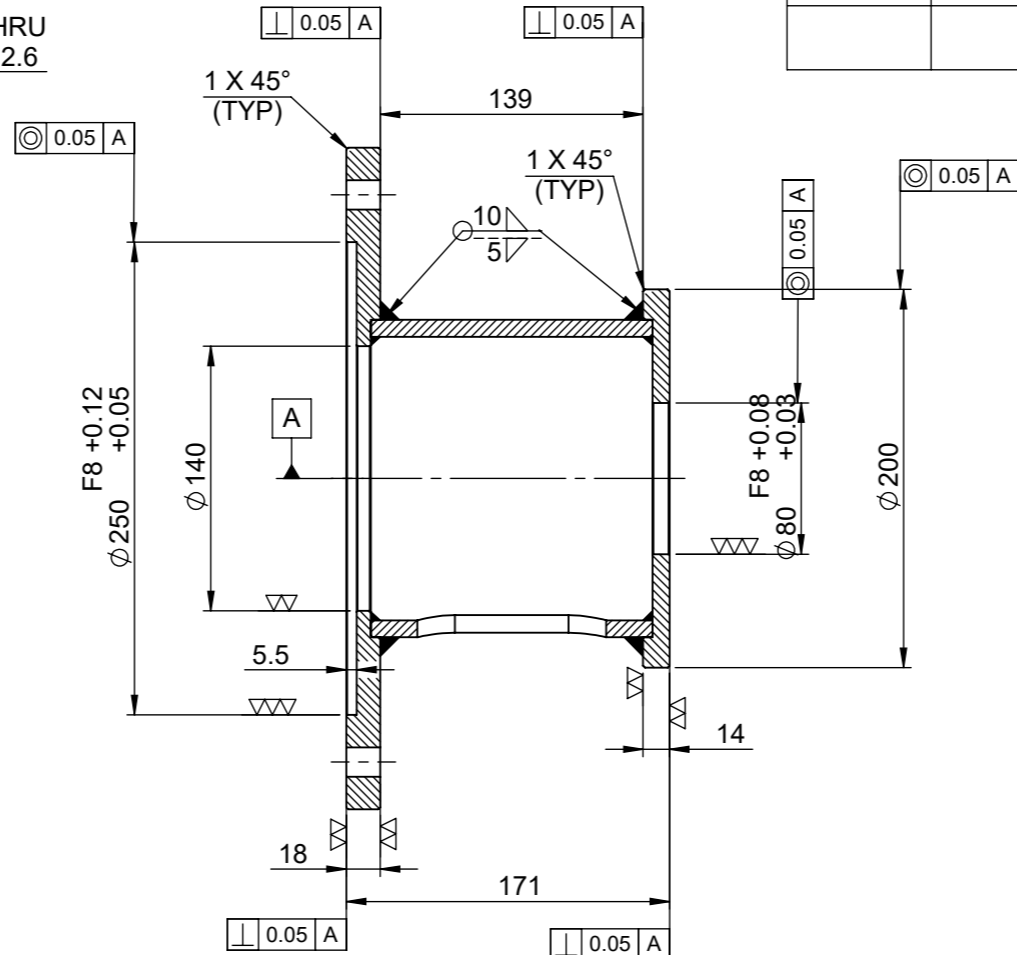
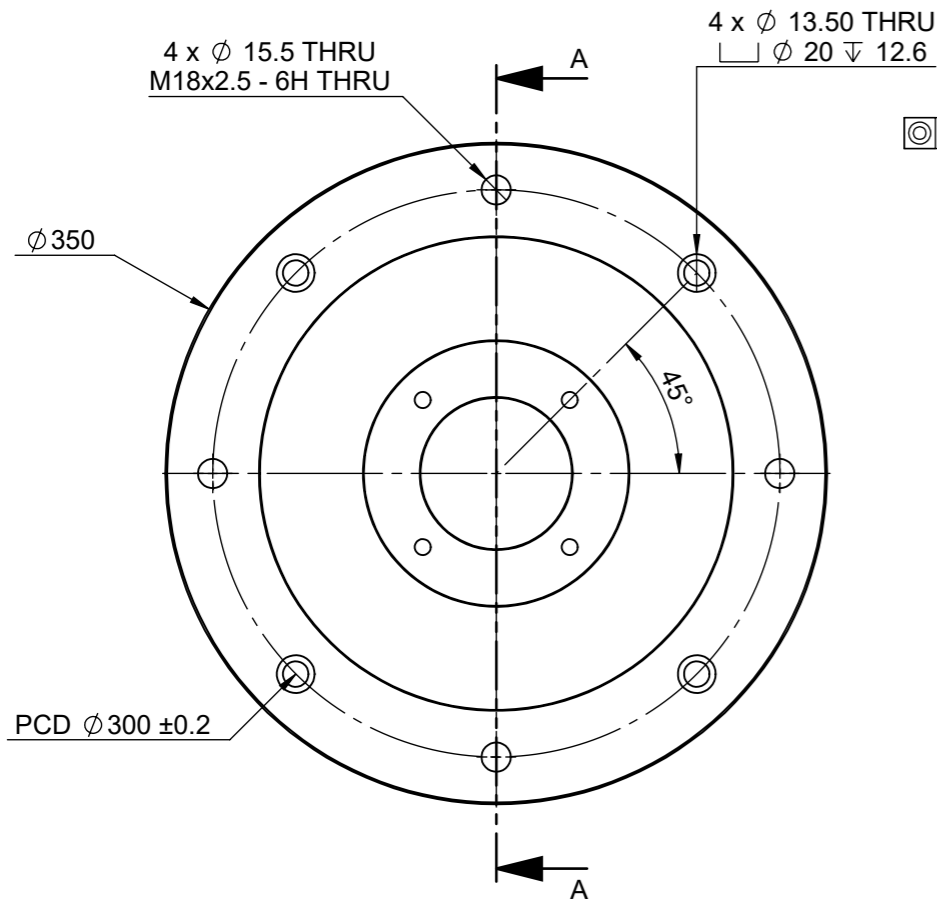

Technical Specification of Bell Housing

01	Total Length & all Critical Bores Should be Finished in Single Setting after Welding
02	Remove all Sharp Corners & De-Burr all Over
03	Gap b/w Adjoining Plates should not be more than 0.05mm
04	Unless Otherwise Specified, Welded Size = 4 to 5 mm All Over
05	All Welds to be finished by Grinding & no Splatter, Slug is acceptable on the Metal Surface
06	Surface Grinding to be done wherever marked with 1.6a
07	Milling to be done wherever Marked with 3.2a
08	Internal Surface of the should be Thoroughly Cleaned by Metal Wire Brush & Corrosion should not be Present on the Metal Surface
09	All the Cutouts Should be Finished to Give(Skin-Cut) Aesthetic Finish
10	Key Way to be Provided for the Coupling Alignment Cutout
11	Mark the Tapped Hole Positions using The Cover Plate as Template & The Exact Mating of Holes Should be Provided
12	All the Tapped Holes Should be Thoroughly Checked Using the Respective Gauges.
13	Fasteners are to be Provided for All the Loose Items.
14	Bell Housing to be Painted with Epoxy Gray Primer before Dispatch
15	All Machined Surface to be Protected Using Rust Preventive Oil.

ITEM NO.	PART NUMBER	DESCRIPTION	Material	Weight	QTY.
1	RE0007007-01	Motor Side Flange Ø350 x 16mm	IS 2062 E250 A	9.4	1
2	RE0007007-02	Pump Side Flange Seamless Ø200 x 14mm	IS 2062 E250 A	2.2	1
3	RE0007007-03	Seamless Pipe Ø168 x Ø150 x 149mm	IS 2062 E250 A	5.0	1

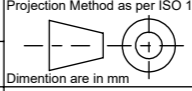
 <p>KP SMART ENGINEERING SOLUTIONS</p>	Title : BELL HOUSING	
	Description : 15 HP Electric motor + PPV100S 16 Piston Pump	
Material Denomination	Material REF. BOM	Quantity 01 Weight Kg 16.6
Approved by Bhavika Patel	Date 07-03-2024	 <p>Treatment According to</p>
Checked by Bhavika Patel	Date 07-03-2024	
Designed by Nirmal Patel	Date 07-03-2024	
Scale 1 : 4		Drawing Number RE0007007
This Drawing is our property, it can not be reproduced or communicated without our written consent.		
Rev.		00

